

CORNER WORKBENCH TCU-1515

Teclab workbenches share common design features that have earned for Teclab the reputation in the industry as the “professional’s bench.” Typical features include an abundance of grounded outlets within easy reach; an infinite variety of drawer and door combinations to meet every job and storage requirement; expansive work surfaces, shelves, and back guards in a choice of task-oriented materials.



HEIGHT TO WORK SURFACE 35"
OVERALL HEIGHT 56 1/4"
BASED ON A 1 1/4" THICK WORK SURFACE.
HEIGHT VARIES DEPENDING ON THICKNESS.

DIMENSIONS

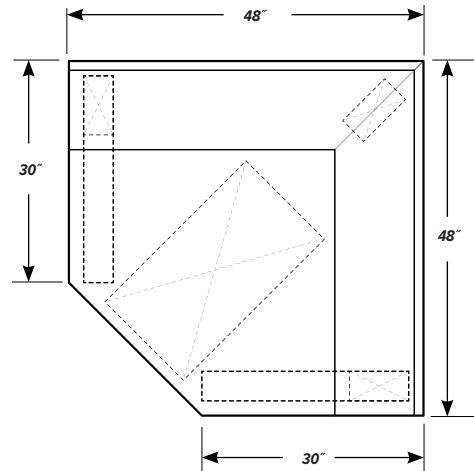

FEATURES

Two **PL-15** Panel Legs

Two **CSB-18** Countertop Support Brackets or one **LEG-15** Support Leg (shown), if unit is not against a wall.

Three **SS-16-EP-1** 16" tall Shelf Supports with 5 grounded 15A outlets, plus combination circuit breaker rocker switch.

One **APD-1500** 15" wide Apron Drawer

One **CTP1-3048X48-PVC** 30" x 48" x 48" 5 sided 1 1/4" plastic laminate Corner Work Surface

Two **SP1-1248-45-PVC** 12" x 48" x 1 1/4" Corner Shelves of same material

Two **BGP-46.75-PVC** 4" x 46 3/4" x 1 1/4" Back Guards of same material

Two **BGP-48-PVC** 4" x 48" x 1 1/4" Back Guards of same material

FINISH OPTIONS

Powder coated steel components.

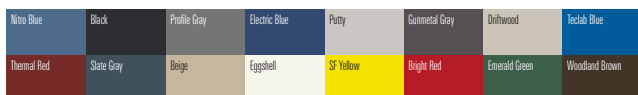

Custom paint color matching is available. Stainless Steel is also available.

WORK SURFACE COLOR OPTIONS

Visual comparison. Color choices vary depending on work surface type.

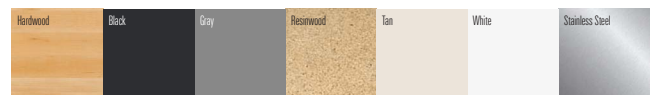

PD - TCU-1515 - v.1.6