

## 8' WORKBENCH TWS-2300

Teclab workbenches share common design features that have earned for Teclab the reputation in the industry as the “professional’s bench.” Typical features include an abundance of grounded outlets within easy reach; an infinite variety of drawer and door combinations to meet every job and storage requirement; expansive work surfaces, shelves, and back guards in a choice of task-oriented materials.

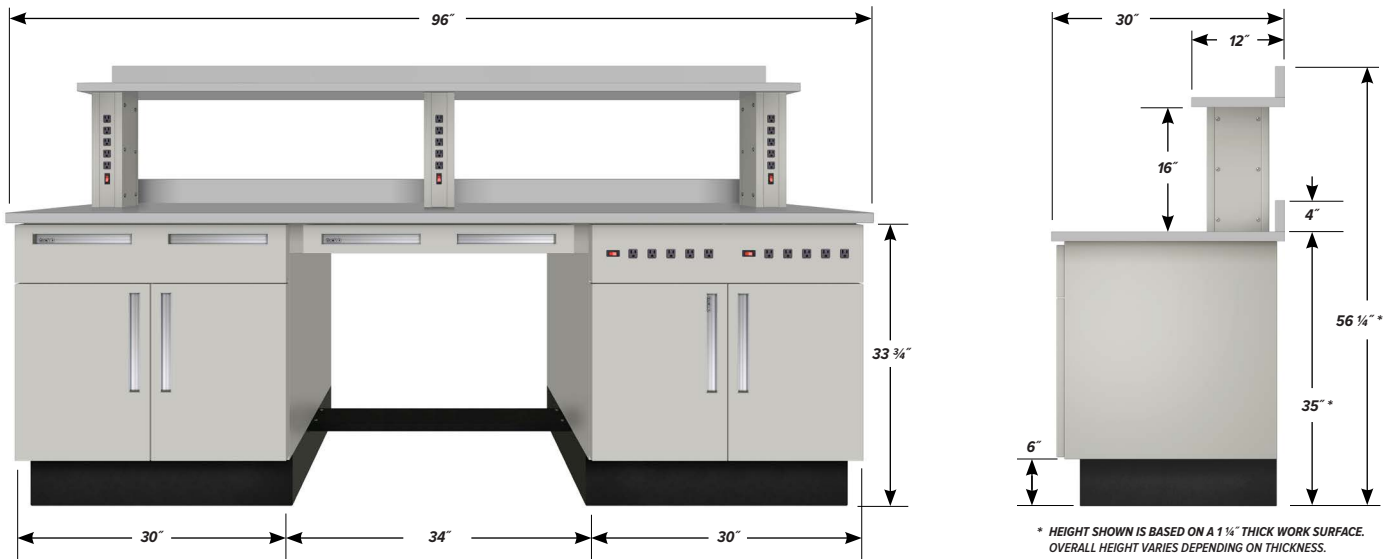

### FEATURES

One **C-3007** one drawer, two door, 30” wide Base Cabinet

One **C-3010-EP-1** two door, 30” wide Base Cabinet with 10 grounded outlets, plus combination circuit breaker rocker switch.

One **FR6-34** 34” Foot Rest

One **APD-3000** 30” wide Apron Drawer

Two **AF-02** 2” Apron Fillers

Three **SS-16-EP-1** 16” tall Shelf Supports with 5 grounded 15A outlets, plus combination circuit breaker rocker switch.

One **TP1-3096-PVC** 30” x 96” x 1 1/4” plastic laminate Work Surface

One **SP1-1296-PVC** 12” x 96” x 1 1/4” Shelf of same material

Two **BGP-96-PVC** 4” x 96” x 1 1/4” Back Guards of same material

### FINISH OPTIONS

Powder coated steel components.

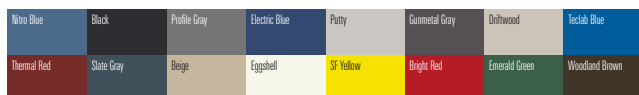

Custom paint color matching is available. Stainless Steel is also available.

### WORK SURFACE COLOR OPTIONS

Visual comparison. Color choices vary depending on work surface type.

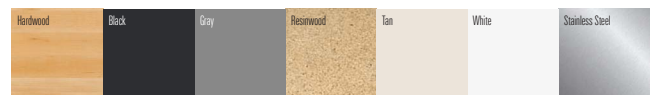

PD - TWS-2300 - v.1.12