

HANGING BASE CABINET UTS-1507

Teclab Base Cabinets are constructed of only top quality, heavy-duty, furniture-grade, cold-rolled steel, double-braced and welded at all critical joints; twin full-perimeter frames formed of heavy gauge steel, welded to provide strength and rigidity; heavy-duty drawers that glide effortlessly on precision steel ball bearings; cabinet doors that open and close with authority and precision using self-closing hinges; brushed aluminum pulls that are recessed for clean lines and unobtrusive operation; durable, textured paint finish, in a wide selection of mar-resistant, easy-to-clean colors.

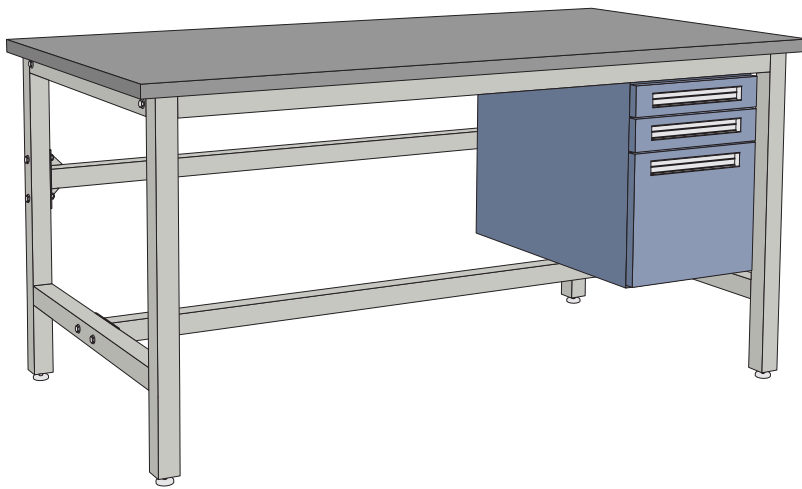

UTS-1507 FEATURES

Two "A" drawers, one "C" drawer.

Cabinet Dimensions: 15" wide, 20 7/8" high, 28" deep

"A" Drawer

Drawer Face Dimensions: 15" wide, 3 1/4" high, 1" thick.
 Drawer Body Inside Dimensions: 12" wide, 2" high, 25 1/2" deep.
 Weight Capacity: 75 lbs.

Top "A" drawer can be replaced with a writing surface.

"C" Drawer

Drawer Face Dimensions: 15" wide, 13 1/2" high, 1" thick.
 Drawer Body Inside Dims.: 12" wide, 9 1/2" high, 25 1/2" deep.
 Weight Capacity: 75 lbs.

All 15" wide "C" drawers accept standard hanging files.

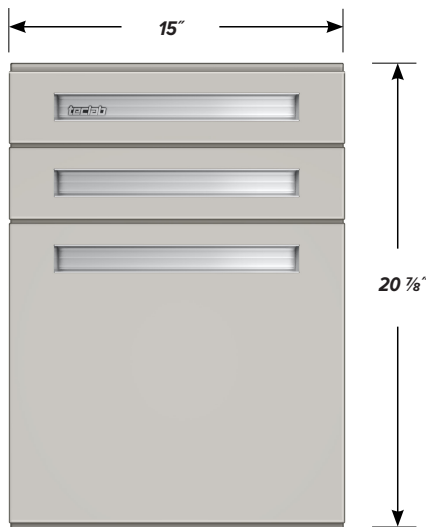

FRONT



SIDE