

## MAGNIFYING TASK LIGHT (LMG-2230)

Magnifier with 45" arm length, a 3-diopter lens and a table/desk base mount.

LMG-2230 has a heavy-duty, all-metal construction with a sleek design, adjustable arm and excellent light output making it suitable for a variety of industrial applications.

### Excellent optics

A 5" diameter optical-quality glass lens combined with powerful LED light-source, makes LMG-2230 one of the best multi-purpose heavy-duty round lens magnifier on the market today. The quality and exact positioning of the LEDs allows for virtually shadow-free magnification and excellent color rendering.

### Maximum flexibility and precision

No knobs to tighten, nothing to adjust. A flexible, self-balancing shade and hands-free neck design allow the lamp head to be secured in any position. The spring-balanced arm provides maximum vertical and horizontal movement, and will always stay in the right position without drifting.

### FEATURES:

- 9-watt dimmable LED
- 3000 lux at 13" focal length
- 4000K
- Auto shut-off
- 3-diopter (1.75X) lens
- 5" diameter optical quality glass lens
- 45" internal spring arm
- Flexible, self-balancing shade and hands-free neck design allows the lamp head to be secured in any position
- Edge clamp base
- Color: Black
- Voltage: 120v
- UL/cUL listed
- Weight: 13 lbs.
- 5 year warranty

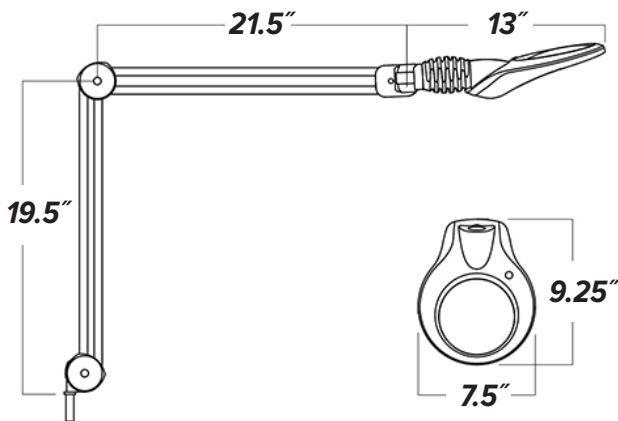

Head: Bottom View



Country of Origin: Norway

PS - LMG-2230 - v.1.2