

POWERED BACK GUARDS

Powered Back Guards (variable length x 4" H x 2" D) are available in lengths to match the length of the work-surface or shelf and come standard with Electrical Power Kit EP-1. Many other EP kits are available as well as data connectors. We can also customize the kits by adding USB charging ports, video ports, etc.

Powered Back Guards are typically mounted onto a work surface, but we also produce wall mounted versions.

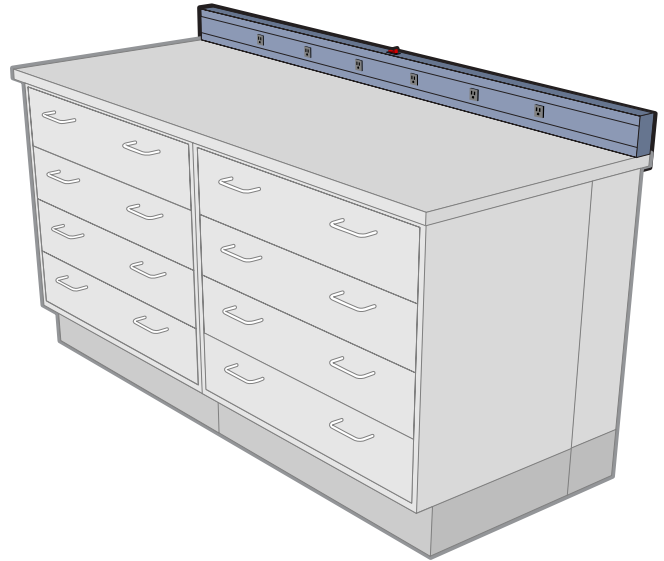

Power Cord Routing:

EP kits come with a 9' Power Cord which can be routed through knockouts on the sides and rear of the back guard. Holes in the bottom can also be used to route cords, though drilling through work-surfaces is required.

Holes and knockouts are standard size and allow easy connection to electrical conduit fittings.

